

# PRODUCT SHEET

## Description:

Magnet Touch Latch Slim Black,  $\varnothing 84 \times 14 \text{ mm}$  20 or 40mm Extension By Switch Tap, w/Square Striker With Adhesive Tape On One, Side & Screw Hole On Other Side, White RAL 9010 Plastic, Incl., Screw For Striker, Screw-On Type

## Item number:

22.01.105-2

Units	Box	Carton	HS Code	Barcode
Pcs.	100	1000	3903300000	
				5704866490160

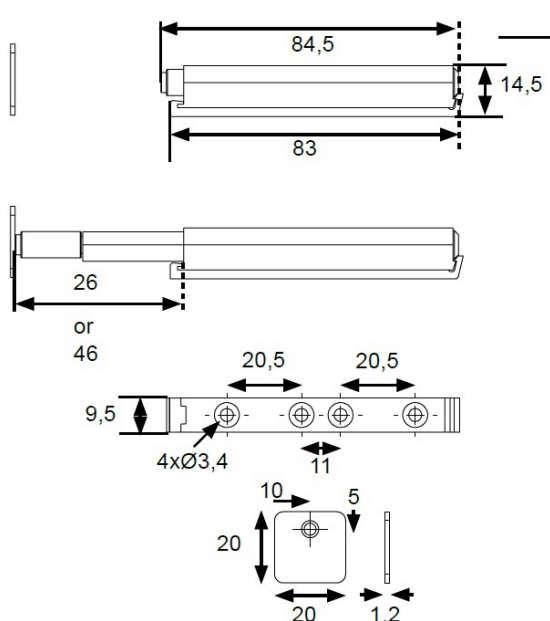

## CHANGE OF EXTENSION LENGTH

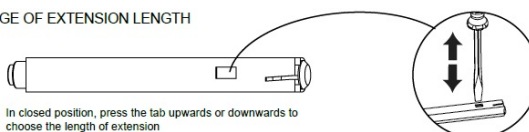

## 20 mm. extension

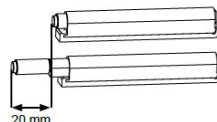

## 40 mm. extension

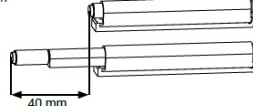

## Mounting of latch

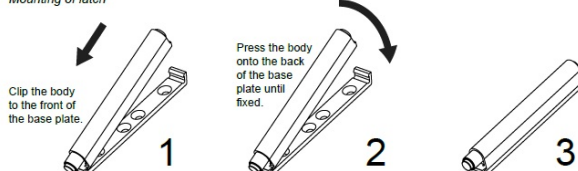

## SISO A/S

Mileparken 11  
DK-2740 Skovlunde  
Denmark  
VAT: DK 24786013

Phone +45 45 830 900

www.siso.dk  
siso@siso.dk

Danske Bank  
Nytorv Branch  
Copenhagen  
SWIFT: DABADKKK

Account no.  
4180 3112 112936  
IBAN Account  
DK7230003112112936